



REMOTE DISPLAYS

*Clear and Bright
Weight Readouts for
Optimal Distance
Viewing*



Model 180
0.56" High Readouts - Page 2



Model RD2
2.25" High Readouts - Page 2



Model SB250
2.6" High Readouts - Page 4



Model SB500
5" High Readouts - Page 3

MODEL RD2 REMOTE DISPLAY

2.25"/57mm High LED • 3 Navigation Keys
 Auto-Learn Feature Selects Input Protocol
 RS232 Interface • 10 Levels of Brightness
 Compact Size • Versatile Mounting Bracket

Whether your application necessitates monitoring weight on tanks, bins, vehicle scales or process control systems, the RD2 includes an RS-232 serial interface that is configurable to meet the communication requirements of your weight instrumentation. The rugged stainless steel enclosure is rated NEMA4/IP66 for added protection from water and dust inherent in industrial environments.



Model RD2

Display..... Six-digit, seven-segment, 2.25" / 57 mm high LED
Power..... 94 to 264 VAC, 47/63 Hz Universal Input
Annunciators..... lb, kg, T, t, G, N
Interface..... 20mA current loop, RS-232
Display Capacity..... 99999 to 999999
Enclosure..... Stainless steel
Enclosure Rating..... NEMA 4 / IP66
Viewing Range..... 150' / 46 m
Operating Temp..... -10 to 120° F (-23 to +49° C)
Shipping Weight..... 16 lb / 7.3 kg

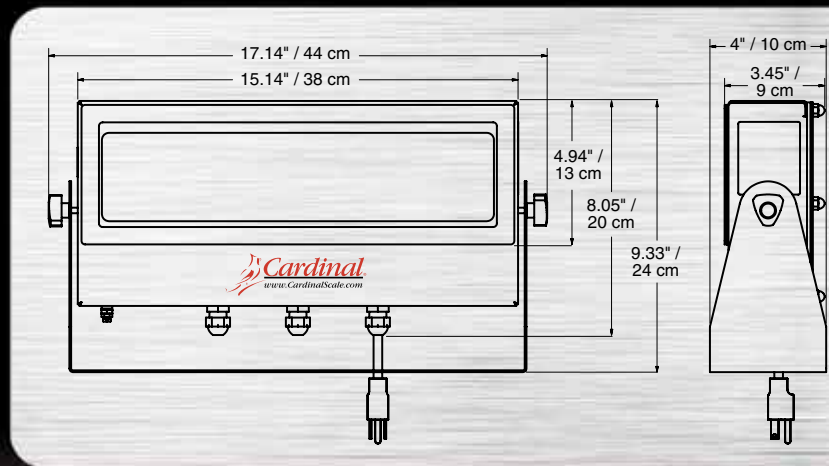

MODEL 180 REMOTE DISPLAY

0.56"/14mm High LED • On-Demand Serial Data
 Continuous Serial Data • Indoor/Outdoor Use
 Stainless Steel Enclosure • Versatile Mounting Bracket

Designed for economy-based applications with a close viewing range, Cardinal's 180 remote display features a bright-red LED, stainless steel enclosure, and versatile mounting bracket for wall or desktop use.



Model 180

Display..... Six-digit, seven-segment, 0.56" / 14 mm high LED
Power..... 12 VDC 1A UL/CSA listed AC power supply
Annunciators..... lb, kg, oz
Interface..... 20mA current loop, RS-232
Display Capacity..... 99999 to 999999
Enclosure..... Stainless steel
Enclosure Rating..... NEMA 1 / IP40
Viewing Range..... 20' / 6 m
Operating Temp..... 14 to 104° F (-10 to +40° C)
Shipping Weight..... 3 lb / 1.3 kg

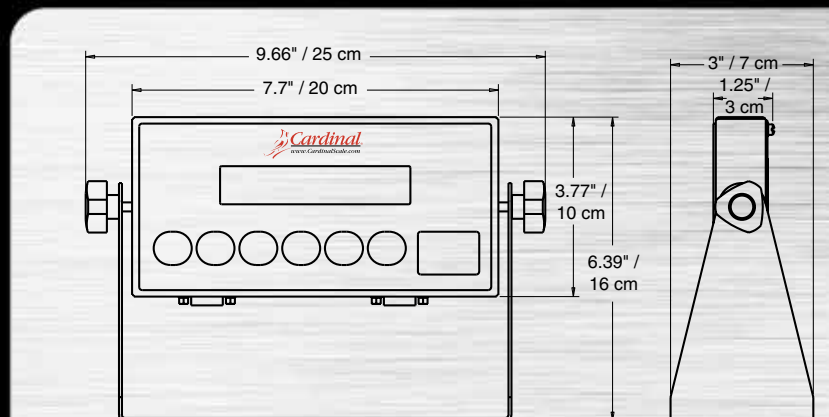

- 5"/127mm High LED
- Mounting Tabs
- Clear Readouts
- Built-in Rain Hood
- Traffic Coordination
- Long Range Visibility
- NEMA 4/IP65 Enclosure

MODEL SB500 REMOTE DISPLAY

SB500M with message board capabilities also available.



Model SB500

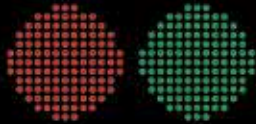

RED/GREEN LIGHT

Configurable control of Stop/Go light traffic signal via serial message or OPTO-22 plug-in relay.



EXTRA-LARGE DIGITS

Large 5-inch-high LED digits, 2-inch-high units (lb, kg, tn, t) and mode (g, t, n) digits with 5-inch-high Stop/Go light.



CONNECTIVITY

Serial (RS-232, RS-422, RS-485, 20mA), fiber optic, wireless, Ethernet, or Wi-Fi plus autolearn mode for most indicators.



BUILT-IN RAIN HOOD

NEMA 4/IP65 enclosure with built-in rain hood protects against harsh elements. Stainless steel enclosure optional - SB500S.



LIGHT SENSOR

Onboard intensity sensor automatically adjusts to ambient light with 10 levels of brightness. 140° horizontal viewing angle.



DAISY CHAIN

Multiple SB500 displays may be daisy-chained together for viewing multiple axles and total weight simultaneously.

Display	Six-digit, seven-segment, 5" / 127 mm high LED
Power	115/230 VAC 50/60 Hz
Annunciators	lb, kg, T, t, G, N
Interface	20 mA, active or passive, RS232, RS422/485, fiber optic, ethernet
Display Capacity	-99999 to 999999
Enclosure	SB500 and SB500M Painted mild steel SB500S Stainless steel
Enclosure Rating	NEMA 4 / IP65
Viewing Range	250' / 76 m
Operating Temp	-15 to 130° F (-26 to +54° C)
Shipping Weight	39 lb / 17.6 kg



Model SB500S

Stainless steel protection against corrosion and harsh environments.

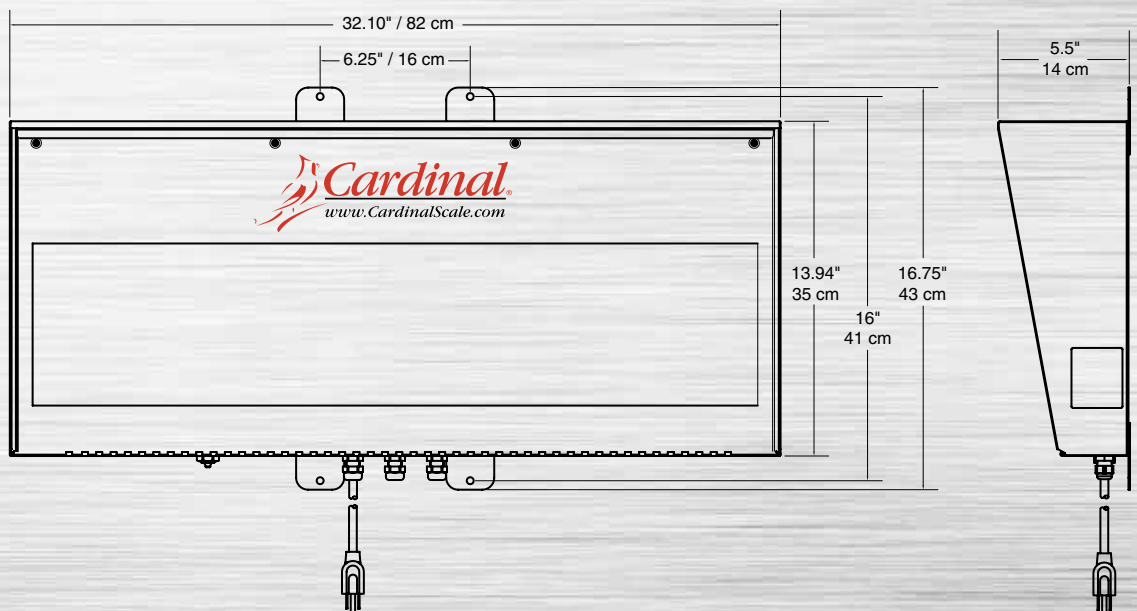

SB500

SPECS



- 2.6"/66mm High LED
- Mounting Tabs
- Clear Readouts
- Autolearn Mode
- Built-in Rain Hood
- 10 Levels of Brightness
- NEMA 4/IP65 Enclosure
- Message Board Standard

MODEL SB250 REMOTE DISPLAY

Model SB250

The SB250 employs many of the same features as the SB500, but in a slightly smaller package. These remote displays feature 2.6-inch-high digits consisting of nine 5 x 7 alphanumeric characters for readouts of upper and lower case letter messages. Cardinal's own *Smart Configuration* software allows custom formats. The integral rain hood provides extra protection and greater visibility during inclement weather. The SB250 features ten levels of display intensity which adjust automatically via an ambient light sensor, ensuring readability both day and night.

Display..... Six-digit, seven-segment, 2.6" / 66 mm high LED

Power..... 115/230 VAC 50/60 Hz

Annunciators..... lb, kg, T, t, G, N

Interface..... 20 mA, active or passive, RS232, RS422/485, fiber optic, ethernet

Display Capacity..... -99999 to 999999

Enclosure..... Painted mild steel

Enclosure Rating..... NEMA 4 / IP65

Viewing Range..... 200' / 61 m

Operating Temp..... -15 to 130° F (-26 to +54° C)

Shipping Weight..... 20 lb / 9 kg



Message board capabilities are standard with all Cardinal SB250 remote displays.



DAISY-CHAIN MULTIPLE UNITS

Cardinal's SB250 and SB500 allow multiple weight data to be viewed while being powered by a single weight display.

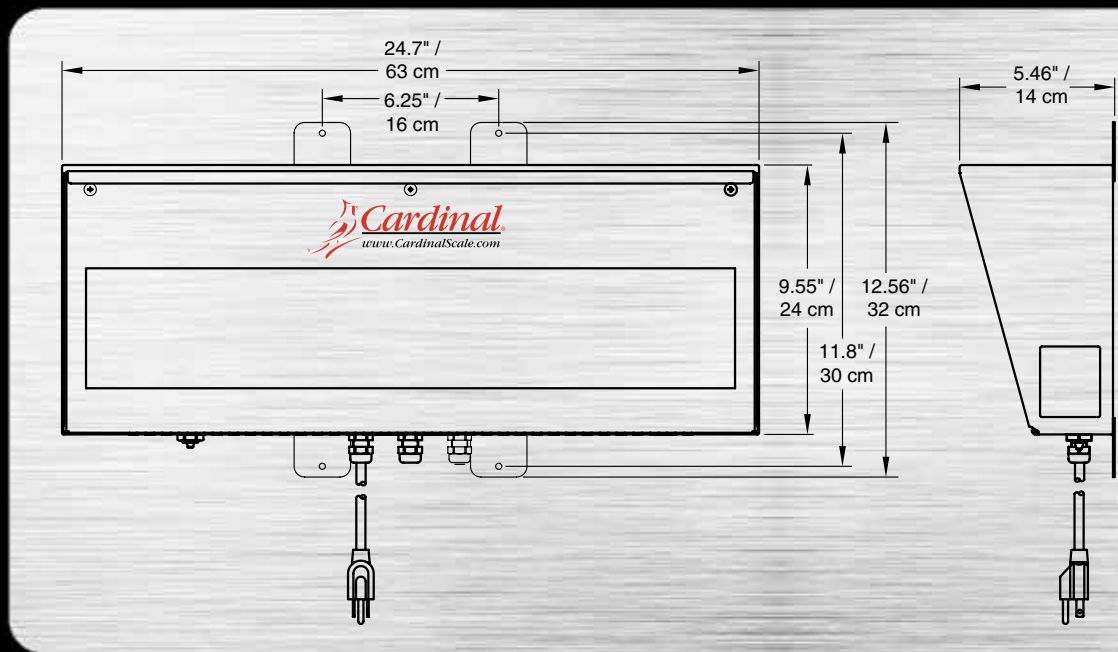

Cardinal Scale reserves the right to improve, enhance, or modify features and specifications without prior notice.

Cardinal
Cardinal Scale Manufacturing Co.
203 E. Daugberty, Webb City, MO 64870 USA
Ph: 417-673-4631 or 800-441-4237 • Fax: 417-673-5001
www.CardinalScale.com

Sold By:

